

## Assembly Instructions for the Texas Hunter Swivel Chair

- 1** Attach legs to the swivel. (Use 1/4"x3/4" bolts, lock washers, and nuts on all leg assemblies.) Insert 3/16"x7/8" nylon spacers between inner holes on leg and inner holes on swivel. Inner bolts are inserted through the legs, through the nylon spacers, and into the fixed nut on the swivel. Outer bolts are inserted through the swivel, through the legs, and secured with a lock washer and nut. Attach cross-braces to legs and to each other at center holes.

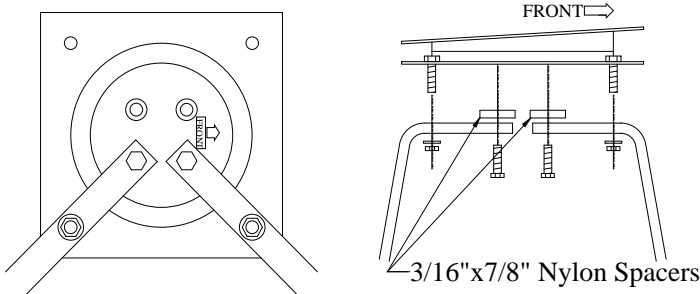

- 2** Turn seat bottom & leg assembly upright as shown below. Attach arms to the seat bottom using 1/4" x 1-1/2" bolts from the arm through the seat bottom. Use a flat washer between the seat and the lock washer and nut.

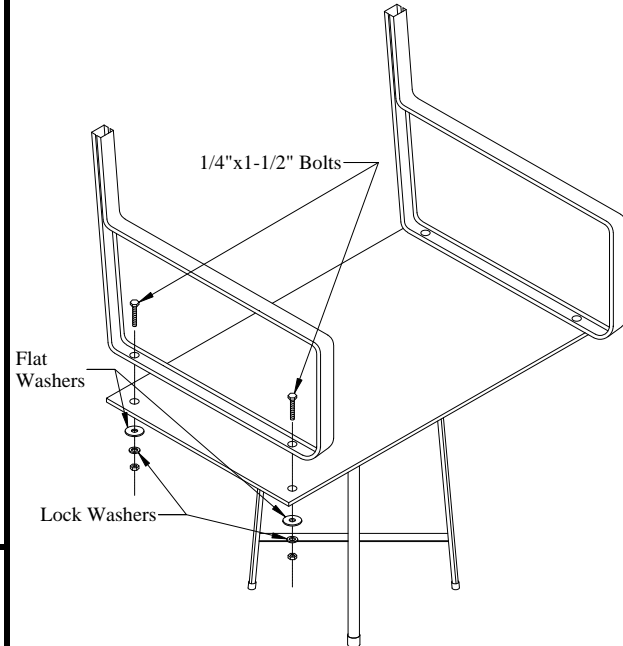

- 3** Insert seat back between arms and attach using 1/4" x 2" bolts, lock washers and nuts.

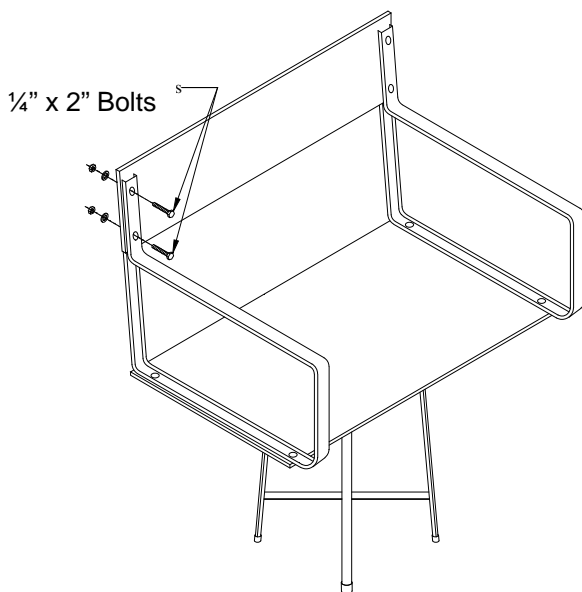

### Parts List

Qty	Description
15	1/4" x 20 x 3/4" Hex head bolts
4	1/4" x 20 x 1 1/2" Hex head bolts
4	1/4" x 20 x 2" Hex head bolts
20	1/4" x 20 Heavy hex nuts
25	1/4" Split lock washers
4	1/4" USS Flat washer
4	3/16" x 7/8" Nylon spacer